

EnVivo

User manual

Bluetooth Soundbar



AFTER SALES SUPPORT



GB

0844 800 5893

IRE

1890 917 060



accessionx-uk@teknihall.com

MODEL: 1340

PRODUCT CODE: 63371

11/2014

3

**YEARS
WARRANTY**

CONTENTS

- Bluetooth Soundbar
- 3-pin UK power adaptor
- Remote control
- Optical cable
- RCA audio cable
- Line-in cable
- Wall mount kit
- User Manual

CONTENT

Welcome.....	3
Warnings and Precautions	3
Important Safety Instructions.....	5
Specifications.....	5
Setup.....	5
Introduction	7
Audio inputs.....	8
Line In	9
Bluetooth Connection	10
Disposal	11
Warranty card	12

PLEASE NOTE

A low call rate number will be available shortly.

For details please check:

http://www.accessionx.com/en/retail/partners/hotlineafter_sales_service/

AFTER SALES SUPPORT		
	 0844 800 5893	
 1890 917 060	accessionx-uk@teknihall.com	
MODEL: 1340	PRODUCT CODE: 63371	11/2014

3
YEARS
WARRANTY

CONTENTS

- Bluetooth Soundbar
- 3-pin UK power adaptor
- Remote control
- Optical cable
- RCA audio cable
- Line-in cable
- Wall mount kit
- User Manual

WELCOME

You have made an excellent choice with the purchase of this quality EnVivo brand product.

By doing so you now have the assurance and peace of mind, which comes from purchasing a product that has been manufactured to the highest standards of performance and safety, supported by the high quality standards of Accession ApS.

We want you to be completely satisfied with your purchase so this EnVivo product is backed by a comprehensive manufacturer's 3-year warranty and an outstanding after sales service through our dedicated Helpline.

We hope you will enjoy using your purchase for many years to come.

If you require technical support or in the unlikely event that the purchase you have made is faulty, please telephone our Helpline for immediate assistance. Faulty product claims made within the 3 year warranty period will be repaired or replaced free of charge provided that you have satisfactory proof of purchase (keep your till receipt safe!) This does not affect your statutory rights. However, be aware that the warranty will become null and void if the product is found to have been deliberately damaged, misused or disassembled.

WARNINGS AND PRECAUTIONS

Warnings

- This appliance is for household, indoor use only.
- To reduce the risk of fire or electric shock, do not expose this apparatus to rain or moisture.
- The warranty for this product is invalidated if the product has been tampered with in any way. There are no user serviceable parts inside this product.
- Do not place this unit directly onto furniture surfaces or soft, porous, or sensitively finished goods. As with any rubber compound made with oils, the feet could cause marks or staining where the feet reside. We recommend using a protective barrier such as a cloth or a piece of glass between the unit and the surface to reduce the risk of damage and/or staining.
- Use of this unit near fluorescent lighting may cause interference regarding use of the remote. If the unit is displaying erratic behavior move away from any fluorescent lighting, as it may be the cause.
- The battery, batteries, and battery pack shall not be exposed to excessive heat such as sunshine, fire, or the like.
- Lithium batteries, like all rechargeable batteries are recyclable and should not be recycled or disposed of in normal household waste. Contact your local government for disposal or recycling practices in your area. They should never be incinerated since they might explode.
- Shock hazard - Do Not Open.

AFTER SALES SUPPORT



0844 800 5893

1890 917 060



accessionx-uk@teknihall.com

MODEL: 1340

PRODUCT CODE: 63371

11/2014

3



**YEARS
WARRANTY**

CONTENTS

- Bluetooth Soundbar
- 3-pin UK power adaptor
- Remote control
- Optical cable
- RCA audio cable
- Line-in cable
- Wall mount kit
- User Manual

Cautions

- To prevent electric shock, match wide blade of plug to wide slot, make sure it is fully inserted.
- Always unplug the appliance from the power outlet when it is not in use and before cleaning. Only use this product with the adapter provided.
- Use of any controls or adjustments or performance of procedures other than those herein specified may result in hazardous radiation exposure.
- Danger of explosion if battery is incorrectly replaced. Replace only with the same or equivalent type.

	<p>WARNING: TO REDUCE THE RISK OF ELECTRIC SHOCK, DO NOT REMOVE COVER (OR BACK). NO USER SERVICEABLE PARTS INSIDE. REFER SERVICING TO QUALIFIED SERVICE PERSONNEL.</p>
	<p>The lightning flash with arrowhead symbol, within an equilateral triangle, is intended to alert the user to the presence of uninsulated "dangerous voltage" within the product's enclosure that may be of sufficient magnitude to constitute a risk of electric shock to persons.</p>
	<p>The exclamation point within an equilateral triangle is intended to alert the user to the presence of important operating and maintenance (servicing) instructions in the literature accompanying the appliance.</p>

AFTER SALES SUPPORT		
	GB 0844 800 5893 IRE 1890 917 060	 accessionx-uk@teknihall.com
MODEL: 1340	PRODUCT CODE: 63371	11/2014



**YEARS
WARRANTY**

CONTENTS

- Bluetooth Soundbar
- 3-pin UK power adaptor
- Remote control
- Optical cable
- RCA audio cable
- Line-in cable
- Wall mount kit
- User Manual

IMPORTANT SAFETY INSTRUCTIONS

1. Read these Instructions.
2. Keep these Instructions.
3. Heed all warnings.
4. Follow all instructions.
5. Do not use this apparatus near water.
6. Clean only with a dry cloth.
7. Do not block any ventilation openings. Install in accordance with the manufacturer's instructions.
8. Do not install near any heat sources such as radiators, heat registers, stoves, or other apparatus (including amplifiers) that produce heat.
9. Please ensure that the power socket and power supply match that stated on the product. Do not modify the plug in any way if these do not match. Consult a suitably qualified electrician if you have any questions.
10. Protect the power cord from being stepped on or pinched particularly at plugs, convenience receptacles, and the point where they exit from the apparatus.
11. Only use attachments/ accessories specified by the manufacturer.
12. Unplug this apparatus during lightning storms or when unused for long periods.
13. Refer all servicing to qualified service personnel. Servicing is required when the apparatus has been damaged in any way, such as power-supply cord or plug is damaged, liquid has been spilled or objects have fallen into the apparatus, the apparatus has been exposed to moisture, does not operate normally, or has been dropped.
14. Do not use the product for any purpose other than its intended use.

SPECIFICATIONS

- 2.0 CH Speaker System
- 32" length
- Bluetooth v2.1
- Wireless range: 33 feet
- Supports Enhanced Data Rate (EDR)
- Supports profile A2DP (Advanced Audio Distribution Profile)
- Digital volume control
- Optical digital audio input
- 3.5 mm audio input
- RCA stereo audio inputs
- Desktop placement or Wall mountable
- Output power: 20W + 20W, total: 40 watts
- Cloth speaker grill
- 3 Sound modes: Movie, Music & Talk (Dialogue enhancement)

PACK CONTENT

- Bluetooth Soundbar

AFTER SALES SUPPORT



0844 800 5893

1890 917 060



accessionx-uk@teknihall.com

3

**YEARS
WARRANTY**

CONTENTS

- Bluetooth Soundbar
- 3-pin UK power adaptor
- Remote control
- Optical cable
- RCA audio cable
- Line-in cable
- Wall mount kit
- User Manual

- 3-pin UK power adaptor
- Remote control: Requires a CR2025 battery (pre-installed)
- Optical cable
- RCA audio cable
- Line-in cable
- Wall mount kit
- User manual

SETUP

Power

AC power input: Requires an AC/DC power adaptor (included)

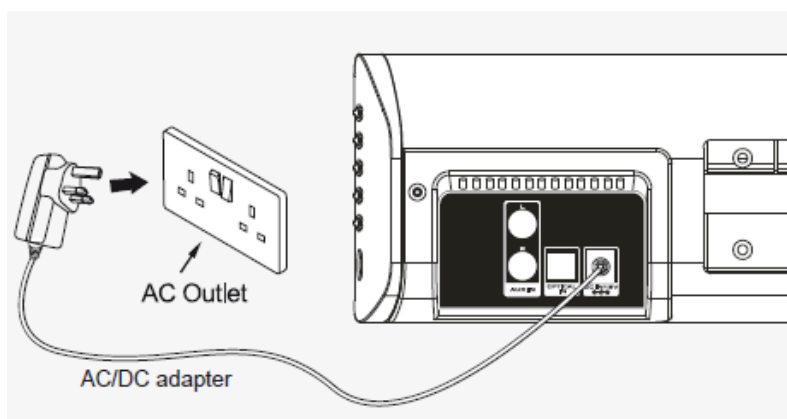

Remote control

Requires a CR2025 battery (pre-installed)

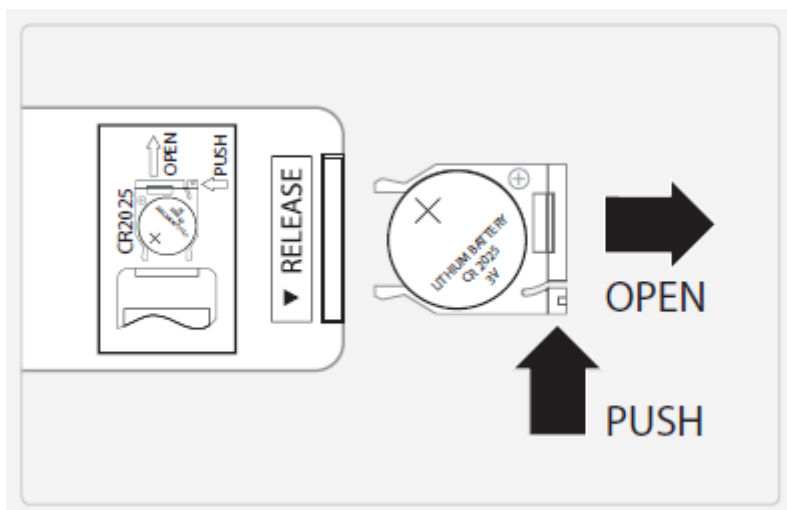

LED indicators

AFTER SALES SUPPORT



0844 800 5893

1890 917 060



accessionx-uk@teknihall.com

3
YEARS
WARRANTY

CONTENTS

- Bluetooth Soundbar
- 3-pin UK power adaptor
- Remote control
- Optical cable
- RCA audio cable
- Line-in cable
- Wall mount kit
- User Manual

Status	Indicators
Power off	Red light
Optical mode	Amber light
AUX in mode	White light
Line in mode	Green light
Bluetooth ready	Flashing light
Bluetooth connected	Blue light

Mounting

Please follow the instructions on the enclosed separate mounting instructions.

INTRODUCTION

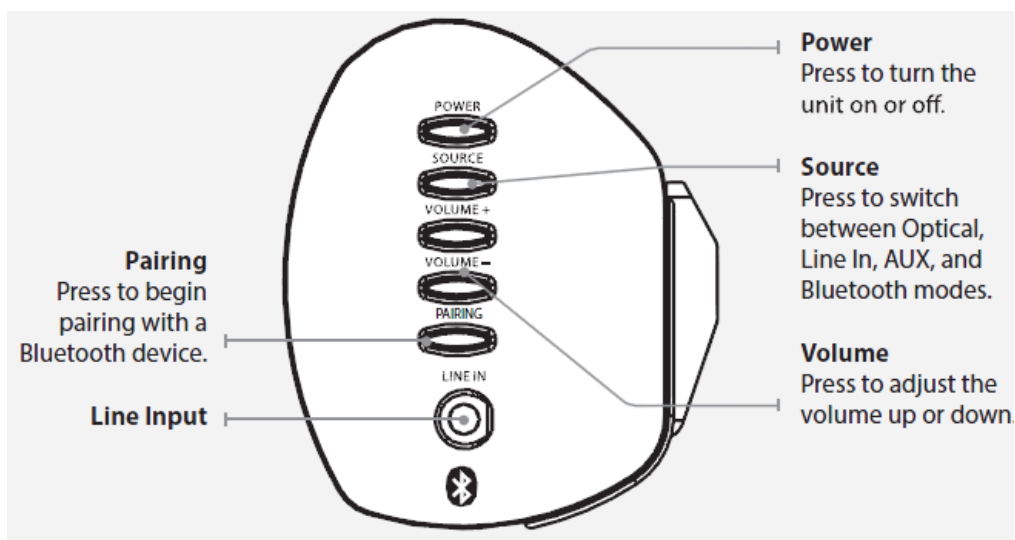
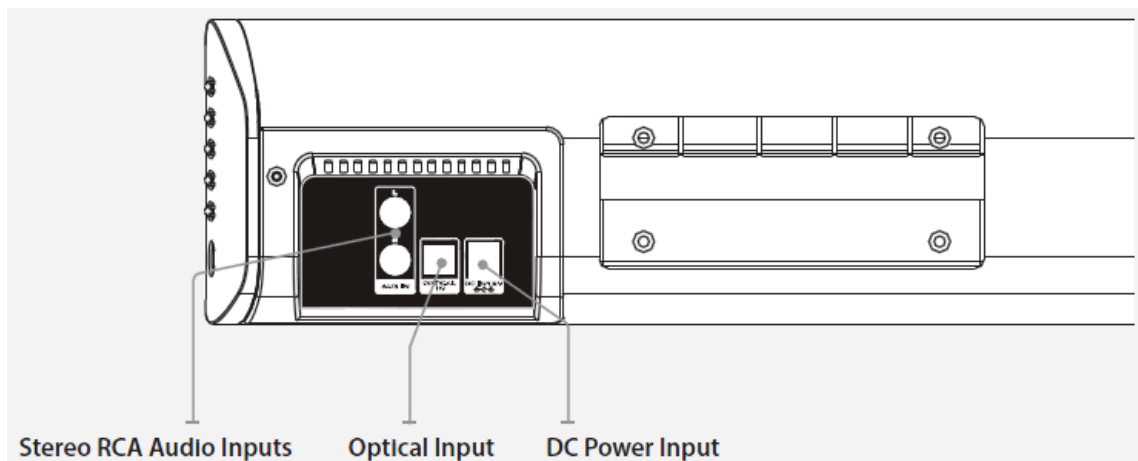

AFTER SALES SUPPORT

 **0844 800 5893**
 **accessionx-uk@teknihall.com**

 **1890 917 060**

3
YEARS
WARRANTY

CONTENTS

- Bluetooth Soundbar
- 3-pin UK power adaptor
- Remote control
- Optical cable
- RCA audio cable
- Line-in cable
- Wall mount kit
- User Manual



AUDIO INPUTS

Using the Stereo RCA Inputs

When connecting two products using an RCA cable, match the colored ports with the same colored connection. Before use, disconnect any cables connected to the Line In.

1. Connect the RCA Cable to the RCA Stereo Inputs located on the back of the unit, and to the audio outputs on the television.
2. Press the **Power** button to power on the unit.
3. Press the **Source** button repeatedly on the soundbar or push **AUX** on your remote control to enter Aux Mode, indicated by a white light.
4. Audio played through the television will now be heard through the speakers.

AFTER SALES SUPPORT



0844 800 5893



1890 917 060



accessionx-uk@teknihall.com

3

**YEARS
WARRANTY**

CONTENTS

- Bluetooth Soundbar
- 3-pin UK power adaptor
- Remote control
- Optical cable
- RCA audio cable
- Line-in cable
- Wall mount kit
- User Manual

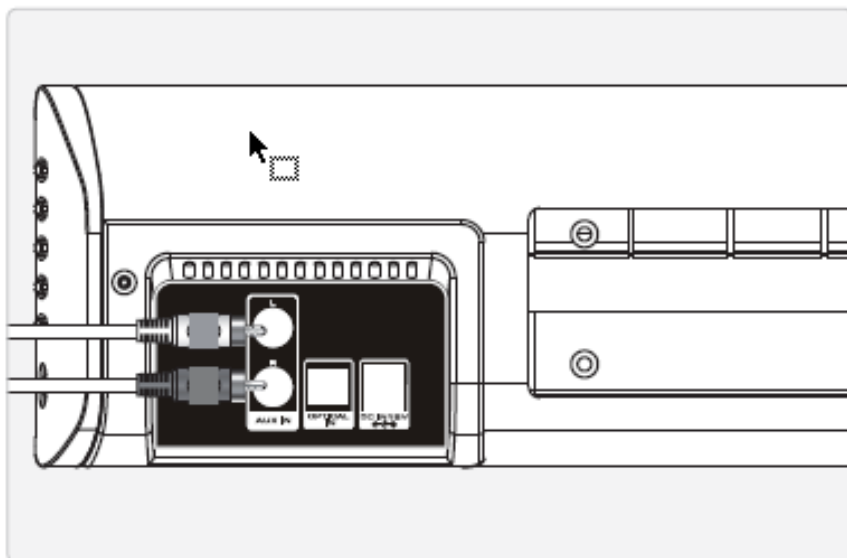

Using the Optical Input

You will need: An audio source with an Optical Audio Output and a Digital Optical Audio cable

1. Connect the Digital Optical Audio cable to the optical output on the audio source and to the **Optical Input** on the speaker bar.
2. Press the **Power** button to power on the unit.
3. Press the **Source** button repeatedly on the soundbar or press **Optical** on the remote control to switch to SPDIF Mode, indicated by an amber light.
4. Using the native controls on your connected device, make sure the audio settings are set to **PCM** or **Optical Audio** and are turned **ON**.
5. Audio from the connected audio source will now be played through the speakers.

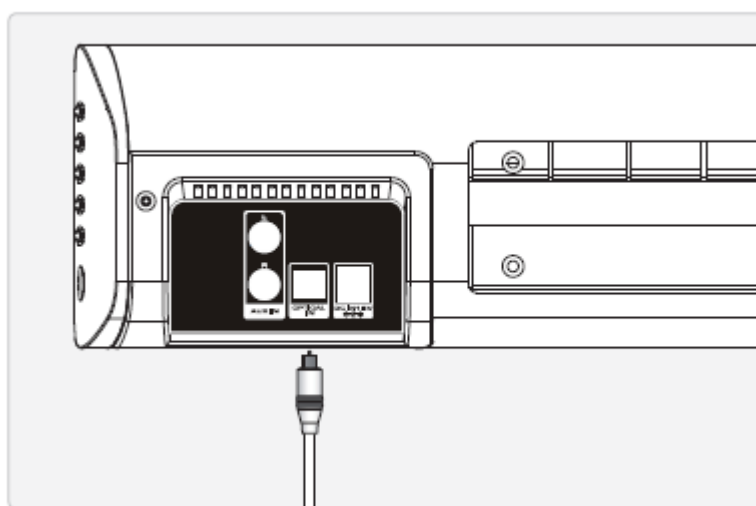

Important tips for optical audio: Use the correct toslink cable and make sure that it is _rmly seated in both source and soundbar sockets. Optical output is activated on the source (they should see a red light

AFTER SALES SUPPORT



GB 0844 800 5893
IRE 1890 917 060



accessionx-uk@teknihall.com

3
YEARS
WARRANTY

CONTENTS

- Bluetooth Soundbar
- 3-pin UK power adaptor
- Remote control
- Optical cable
- RCA audio cable
- Line-in cable
- Wall mount kit
- User Manual

emitting from the toslink socket). It may be labeled SPDIF in the setting menu of the source. The optical output is set to output PCM and not Dolby Digital.

LINE IN

Using the Line In

1. Plug one end of a 3.5 mm audio input cable (included) into the **Line In** on the unit. Before use, disconnect any cables connected to the Stereo RCA Inputs.
2. Plug the other end of the cable into the audio output/headphone output on an MP3 Player or other audio source.
3. Press the **Power** button to power on the unit.
4. Press the **Source** button repeatedly on the soundbar or press **LINE** on the remote control to enter Line In Mode, indicated by a green light.
5. Audio played through the connected device will now be heard through the speakers.

BLUETOOTH CONNECTION

Pairing a Bluetooth Device for the First Time

1. Power on the unit by pressing the **Power** button.
2. Press the **Source** button repeatedly on the soundbar, or press the **Bluetooth** icon on the remote control to enter Bluetooth mode, indicated by a blue light.
3. Press the **Pairing** button on the side of the unit.
*The **Pairing Indicator** will flash blue quickly. When pairing, remain within 3 feet of the unit.*
4. Using the native controls on your Bluetooth device, select the "**SB Speaker**" in your Bluetooth settings to pair.
If your device requests a password, enter the default "0000". Refer to the "user's manual" for your specific device for instructions on pairing and connecting Bluetooth devices.
5. When successfully paired and connected, a beep will issue from the unit and the **Pairing Indicator** will display a solid blue light. After initial pairing, the unit will stay paired unless unpaired manually by the user, or until it is erased due to a reset of the device.
If your device should become unpaired or you find it is unable to connect, repeat the above steps.

Playing Audio Wirelessly

1. Follow the instructions for **Pairing a Bluetooth Device**.
2. Use the native controls on the connected Bluetooth Device to select a track.
3. To play, pause or skip the selected track, use the native controls on the connected Bluetooth Device.
4. Audio played through the connected Bluetooth device will now be heard through the speakers.

AFTER SALES SUPPORT



0844 800 5893
1890 917 060



accessionx-uk@teknihall.com

3

YEARS
WARRANTY

CONTENTS

- Bluetooth Soundbar
- 3-pin UK power adaptor
- Remote control
- Optical cable
- RCA audio cable
- Line-in cable
- Wall mount kit
- User Manual

DISPOSAL



Batteries, electrical and electronic equipment (EEE) contain materials, parts and substances, which can be dangerous to the environment and harmful to human health if waste of electrical and electronic equipment (WEEE) are not disposed of correctly. Batteries, electrical and electronic equipment, which are marked with the WEEE logo (as shown on the left), should not be thrown away with your household waste. Contact your Local Authority Waste Disposal Department, as they will be able to provide details of the recycling options available in your area.



Battery safety:
Do not burn. Risk of explosion.
Do not recharge non-recharge-able batteries.
If swallowed seek immediately medical advice.
Ensure correct polarity.
If not used for extended period remove battery.

AFTER SALES SUPPORT



0844 800 5893
1890 917 060



accessionx-uk@teknihall.com

3

**YEARS
WARRANTY**

CONTENTS

- Bluetooth Soundbar
- 3-pin UK power adaptor
- Remote control
- Optical cable
- RCA audio cable
- Line-in cable
- Wall mount kit
- User Manual

EnVivo

WARRANTY CARD

Bluetooth Soundbar - 63371

Please keep your purchase receipt together with your card.

Name _____

Address _____



Date of purchase _____

Location of purchase _____

Detailed description of malfunction

Accession ApS - Vandmanden 34 - DK - 9200 Aalborg SV

www.accessionx.com